

Articulated Dump Trucks

DA30-7

DA45-7

Maximum power	375 hp	500 hp
Operating weight	51.5 t	71.5 t
Body capacity	17.8 m ³	26.1 m ³



DEVELON

DEVELON

**Continuous evolution,
for better.**

We trace our roots to 1937 as one of Korea's first large-scale machine plants. During that time, we have consistently delivered earth-moving equipment to build critical infrastructure for the betterment of communities, societies and the wider world.

**We are
Develon.**

Develon is a bold name that reflects our core ambition to continue developing onwards and leaving behind a positive footprint in our world. Moving forward, we will continue providing innovative products and solutions that advance the world we live in today.



Big loads, big results with Develon DA30-7

The DA30-7 offers best-in-class ground clearance & ground bearing pressure. Combined with superior torque at low engine rpm and superior power and traction, we offer you the best productivity.

Operator's environment

Ergonomic controls, most spacious cab in the market, high-class seat, Bluetooth radio with USB, and much more...

Operate at ease

Upgraded monitor panel, new control panel for more convenient use, rear-view camera, body tip boost button, etc.

Power

Scania DC 09 engine: 276 kW (375 HP) at 2100 rpm with electronic exhaust brake.

New quality of ride

New self-leveling, hydro-gas suspension supports soft ride in harsh conditions.

Maneuverability

Unique design of rear frame, body, and front-mounted differential on transmission make the Develon machine the most compact ADT in its class, which results in smallest turning radius and outstanding stability.

Differential

Front and rear differentials are limited slip, longitudinal differential can be manually locked by pushing 1 button.

Safety highlights

Gradient meter with body flip-over protection, Body Over Centre of Gravity function, fenders and hand rails all around cab, superior stability and always visible and clean front cab access.

Body

Steel plates with 400 HB hardness. Capacity without/with tailgate: 16.8/17.8 m³. Tailgate, body heating & wear plates available as optional equipment.

Telematics

Monitor your fleet online. As standard, Develon Fleet Management with dual mode (satellite, GSM). Check productivity, fuel consumption, system warnings, maintenance status, etc.

Brake systems

Oil-cooled wet disc brakes (lifetime up to 15000 hours). Standard hydraulic transmission retarder & hydraulic parking brake.

Service accessibility

Diesel, AdBlue and grease (for auto-lube system) filling from ground level. Easy access to filters and oil filling points. Tilttable cab with self-positioning locking mechanism.

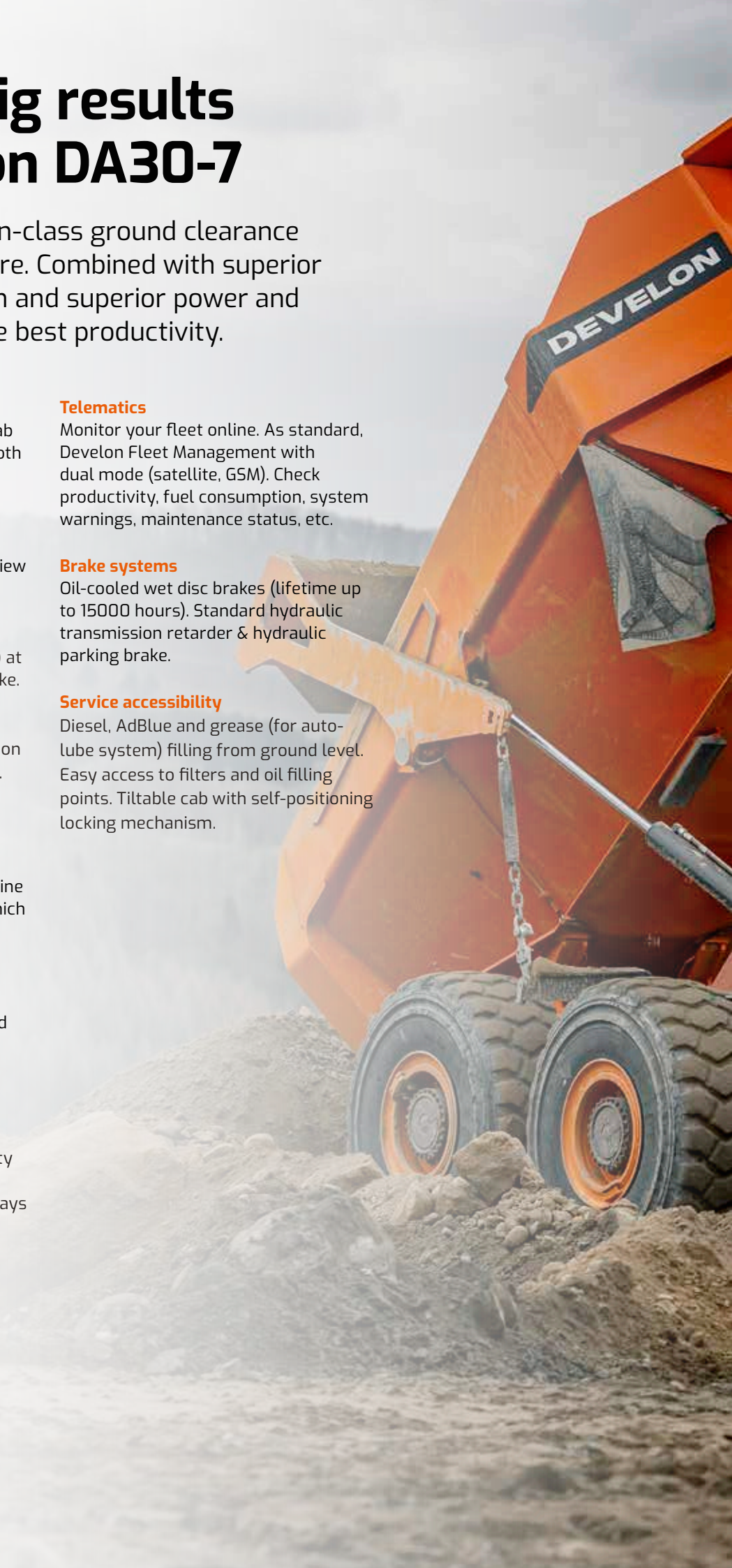



DA30

DEVELON

Develon DA45 is built to handle it all

The Develon DA45-7 offers the best combination of payload and efficiency in its class. Thanks to its unique design, best productivity is delivered in all working conditions.

Operator's environment

Ergonomic controls, most spacious cab in the market, high-class seat, Bluetooth radio with USB, and much more...

Operate at ease

Upgraded monitor panel, new control panel for more convenient use, real-life payload meter with external light indication, rear-view camera, body tip boost button, etc.

Power

Unstoppable Stage V compliant Scania DC13 engine: 368 kW (500 HP) at 2100 rpm.

New quality of ride

New self-leveling, hydro-gas suspension supports soft ride in harsh conditions.

Maneuverability

Unique design of rear frame, body, and front-mounted differential and transmission make the Develon machine the most compact ADT in its class, which results in smallest turning radius and outstanding stability.

Differential

Front and rear differentials are limited slip, longitudinal differential can be manually locked by pushing 1 button.

Safety highlights

Gradient meter with body flip-over protection, Body Over Centre of Gravity function, overload protection system with external traffic lights, fenders and hand rails all around cab, superior stability and always visible and clean front cab access.

Body

Steel plates with 400 HB hardness. Capacity with/without tailgate: 24.5/26.1 m³. Tailgate, body heating & wear plates available as optional equipment.

Telematics

Monitor your fleet online. As standard, Develon Fleet Management with dual mode (satellite, GSM). Check productivity, fuel consumption, system warnings, maintenance status, etc.

Brake systems

Oil-cooled wet disc brakes (lifetime up to 15000 hours). Standard electronic engine brake, hydraulic transmission retarder & parking brake.

Service accessibility

Diesel, AdBlue and grease (for auto-lube system) filling from ground level. Easy access to filters and oil filling points. Tilttable cab with self-positioning locking mechanism.









Drive Efficiency, Haul Success

Productivity in Every Load!

The Develon ADT concept offers a larger load capacity in all weight categories. Additional load capacity, combined with superior power and traction, improve productivity. The unique advantages of the Develon ADT's permanent 6-wheel drive, free-swinging rear tandem, front-mounted turning ring, independent front wheel suspension, and sloping rear frame provide excellent driving stability with equal weight distribution and superior traction. The Develon Articulated Dump Truck is designed to work under very tough conditions and travel up to 55 km/h.

Top performance and fuel efficiency

Engines – lower emissions, same great performance

Develon ADTs use only proven, reliable and powerful diesel Scania engines with excellent torque, which achieve low fuel consumption and fulfill Stage V European regulation requirements.

New self-leveling hydro-gas front suspension

The DA30's design was based on the successful and proven design of the DA45. It has been upgraded with the self-leveling system for better shock absorption in changing operating conditions.

Retarder

Powerful hydraulic retarder keeps machine's speed constant on downhills without support of service brakes. Operator can easily adjust the retarder's power by lever or simply pushing the gas pedal.

Transportability

Thanks to its less than 3-meter width, the DA30 can be moved easily from one site to another. And thanks to the compact design of both machines, a shorter low loader can be used.

Forward-mounted turning ring

The turning ring is located in front of the articulation point, ensuring equal weight distribution to the front wheels in all operating situations, including maximum turning. The equal weight distribution enables you to use the limited slip differentials with only 45% locking value – ensuring drive to both front wheels in all situations, without completely locking the wheels.

Traction

The Develon ADT's unique design offers permanent 6-wheel drive, ensuring stability and equal weight distribution to accommodate all job applications. The Develon ADTs superior driveline ensures maximum traction and durability.



Design simplicity

Permanent 6-wheel drive, together with the ground-following rear tandem and our special front-mounted turning ring, provide equal power & weight distribution and excellent operating performance. The sloping rear frame provides a lower centre of gravity - improving the ADT's overall stability, and ensuring fast and easy tipping of the body for increased productivity.



Drive Smart, Save Fuel



Hauling Comfort, Delivering Ease



Big Truck, Bigger Comfort Zone

The Develon ADT is one of the industry's simplest trucks to operate and, at the same, time offers a large number of functions. Comfortably seated in this class-leading operator cab, you'll enjoy easy operation combined with excellent efficiency. And thanks to the upgraded monitor panel, you'll operate in your comfort zone.

Quietest truck in the industry

The spacious ROPS/FOPS cab is equipped with climate control and a high-quality operator seat with air suspension to provide excellent comfort. Precise steering, good visibility, low noise levels (72 dB(A), ISO6395) and optional vertical movement provide additional comfort and quiet.

- The sloping hood gives the operator an excellent view
- The cab is mounted on a special rubber suspension to reduce vibration and conduction of noise into the cab

Best-in-class operator environment

The new DA30 cab was designed based on the feedback received directly from hundreds of Develon operators. This resulted in upgrade of the cab in features and functions required by the market, including: hand grip on the right side, foot rest, improved storage room, USB charger, Bluetooth radio, all around rails outside the cab, additional lever for retarder control and a number of other new features.

High-comfort air-suspension seat

Because a highly comfortable seat means a lot to every operator, we provide an air-suspension seat with armrest as standard.

One key solution

To enter and safely operate your Develon ADT, you need just 1 key to lock and unlock all the doors and also start the engine.

Self-leveling, hydro-gas front suspension

New suspension system has outstanding performance in rough terrain due to big shock absorption capacity of the hydraulic suspension cylinders. On top of that, the self-leveling system can adjust to match changing working conditions.

Storage compartments with extra 12 V power supply

Plenty of storage spaces, plus extra room designed to fit cool/hot box with additional 12 V power supply.

MP3, DAB and Bluetooth

Standard radio supports all modern features like MP3, DAB and Bluetooth.

Climate control

Our specially designed climate control is easy to operate and highly efficient – keeping you comfortable at all times.

Total control in all simplicity

Do more in less time

- Bigger indications
- Multiple languages
- Integrated payload meter (as standard)
- Diagnostic section with transmission and hydraulic oil level check function
- Gradient meter indication for increased safety while operating
- Integrated rear-view camera

LCD color monitor panel

- 7" color display, resolution 800 x 480 pixels
- Shows all necessary information for driving and handling the machine
- Rear-view camera image embedded in instrumentation graphics
- Backlight dimming according to ambient light conditions
- Sub-menus for additional and diagnostic functions

Touch pad

- Diesel fuel heater ON/OFF
- Longitudinal differential lock
- Override button
- Cab roof and mirror arm front lights ON/OFF
- Rotating beacon ON/OFF (optional)
- Operating work-lights ON/OFF

Differential activation

With automatic limited slip differentials, automatic and manual transmission shift, power steering, "simple touchpad" and "easy to read" display, every ADT is as simple to use & operate as possible.

Body hoist lever

The new body hoist lever is easy to operate and fingertip controlled. This electronically managed hoist lever incorporates a higher body up speed and an automatic body down feature, with soft touch down, to keep you safe at all times.

"Tip-tronic" gear shift

To ensure the smoothest possible gear shifts and momentum, you can run the truck in both automatic and manual gears.

Retarder force modulation lever

New lever located on the right-hand side below the steering wheel enables operator to choose from 4 power modes. On top of that, the gas pedal is responsible for retarder power reduction.



Simple maintenance with great uptime

Access main filling points while standing on the ground

Improved simplicity of maintenance and service reduces failure rate and improves lifetime and longevity. Convenient position of liquids' levels check and filling points, easy access to filters and very low number of rubber wearing components significantly reduce labor time.

Training Center

Located in the heart of Europe, near Prague (Czech Republic), the Develon Academy is a dynamic center of knowledge where Product, Service and Develon University training courses are held.

The facilities include a modern building that can accommodate all of the product ranges, and an outdoor training area where we conduct field exercises and product testing with the fleet of Develon machines and attachments.

Global Develon network

With a network of Develon Dealers & Parts Distribution Centers worldwide, your Develon trucks can be serviced & maintained wherever you are.

Telematics

The Develon Fleet Management system is available for reading out vehicle operating & production parameters remotely, and providing you with total ease-of-mind. Keep day-by-day overview on the machine's productivity, status and condition.

Filters

All filters are centralized for quicker and easier accessibility.



- Easy access to factory-fitted standard automatic central lubrication system
- Dedicated space for grease cartridge and grease gun
- Easy access to filters



- Diesel and AdBlue filling points accessible from the ground level
- Diesel tank prepared for fast fill coupler



- LED light indicates when power isolator can be switched off
- Power isolator in convenient and safe location
- External power supply

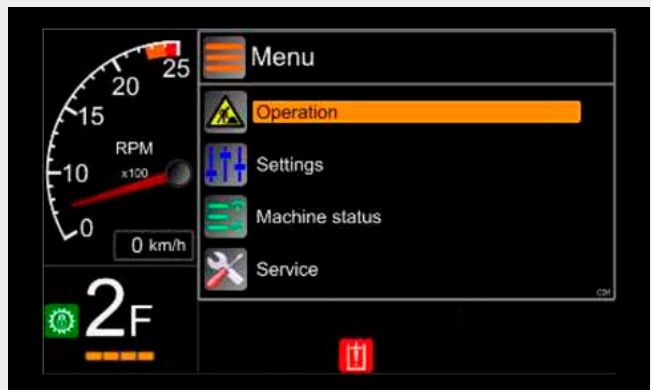

- Multifunctional display with available service/maintenance functions
- Transmission oil level check
- Status of hydraulic and electronic components

Develon Fleet Management > Management on
the job site > Work efficiency management >
Preventive management > Proactive service



Monitor your equipment from anywhere

To compete and succeed, your equipment needs to maximize job site productivity and the bottom line. Develon machines do both. To ensure a high return on investment, we add more premium features as standard equipment on every model. Our standard features are often options that other manufacturers only provide at extra cost. By including them as standard, Develon gives you a competitive edge — helping operators work more efficiently and improving safety during long days on the field.

> Telematics terminal

Terminal device is installed and connected to a machine to capture machine data.

> Telecommunication

Develon provides dual-mode (Mobile, Satellite) communication to maximize communication coverage.

> Develon Fleet Management WEB

Users can monitor machine status from Develon Fleet Management Web.

Operation trend	Total operation hours and operation hours by mode.
Fuel efficiency*	Fuel level and fuel consumption
Reports & Location	Operation report & utilization. GPS and geo-fence.
Warning & Alert	Detect machine warnings, antenna disconnection, and geo/time fence
Filter & Oil management	Preventive maintenance by item replacement cycle.

DEVELON

TECHNICAL SPECIFICATIONS

DA30 DA45



Engine

Model	Scania DC 9	Scania DC 13
No. of cylinders	5 (in line)	6 (in line)
Rated power at 2100 rpm (ISO 3046)	375 HP (276 kW)	500 hp (368 kW)
Rated power at 2100 rpm (ISO 14396)	362 HP (270 kW)	483 hp (360 kW)
Max. torque at 1300 rpm	1873 Nm	2373 Nm
Bore × stroke	130 × 140 mm	130 × 160 mm
Starter	8 HP (6 kW)	
Batteries – Alternator	2 × 12V 140Ah – 24V 100A	

Weights

Empty: Front axle	12500 kg	14500 kg
Empty: Rear axle	10600 kg	16000 kg
Max. admissible axle load: Front axle	16700 kg	22500 kg
Max. admissible axle load: Rear axle	37000 kg	55000 kg
Max. admissible weight	51500 kg	71500 kg
Payload	28 t	41 t
Net weight	23100 kg	30500 kg
Max. traction force (drawbar pull)	48.5 kipf (22.0 ton.f)	

Note: All weights include a full fuel tank and operator.

Ground Pressure

Empty: Front axle	121.7 kPa	93.9 kPa
Empty: Rear axle	51.6 kPa	51.8 kPa
Loaded: Front axle	161.6 kPa	139.2 kPa
Loaded: Rear axle	169.8 kPa	161.3 kPa

Body

Body capacity (without tailgate)	16.8 m ³	24.4 m ³
Material	Hardened abrasion-resistant steel plates (400 HB)	
Tilt cylinders	Single stage, double-acting	
Tipping time	Up: 12 sec. / Down: 10 sec.	
Body	Designed for exhaust heating	
Sloping frame	Down from the hinge point	

Speeds

Forward 1 – 2 – 3 – 4 – 5 – 6 – 7 – 8	6 - 8 - 11 - 16 - 23 - 32 - 45 - 55 km/h	5 - 8 - 11 - 16 - 23 - 32 - 45 - 55 km/h
Rear 1 – 2 – 3 – 4	6 - 8 - 11 - 16 km/h	5 - 8 - 11 - 16 km/h

Transmission

Type	ZF 8 EP320	ZF 8 EP420
------	------------	------------

Power to weight ratio

Empty	11.9 kW/t	11.8 kW/t
Loaded	5.4 kW/t	5.0 kW/t

Fluid Capacities

Fuel tank	335 l	530 l
Hydraulic system	95 l	100 l
Adblue tank	70 l	70 l
Hub front	9.6 l	9.6 l
Tandem housing, rear differential and hubs	155 l	228 l
Cooling circuit	45 l	50 l
Engine	35 l	45 l

Hydraulic system

1 variable displacement piston pump for steering & tipping and for cooling fan, brakes & auxiliaries	305 l/min @ 2100 rpm
Main safety valves pressures / circuit	280 / 210 bar
Filtration	One return flow filter

Tires

Standard	23.5 R25 two star radial	29.5 R25 two star radial
----------	--------------------------	--------------------------

DA30

Unit: mm

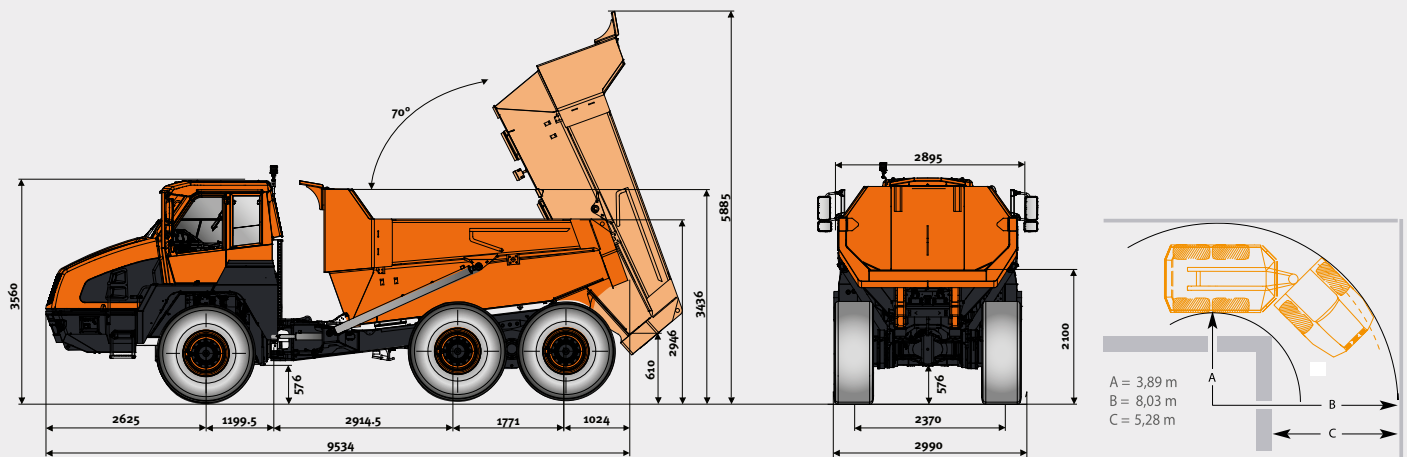

DA45

DA30 width with 750/65 R25 tyres: 3208 mm

Turning radius according to ISO 7457: 7.68 m

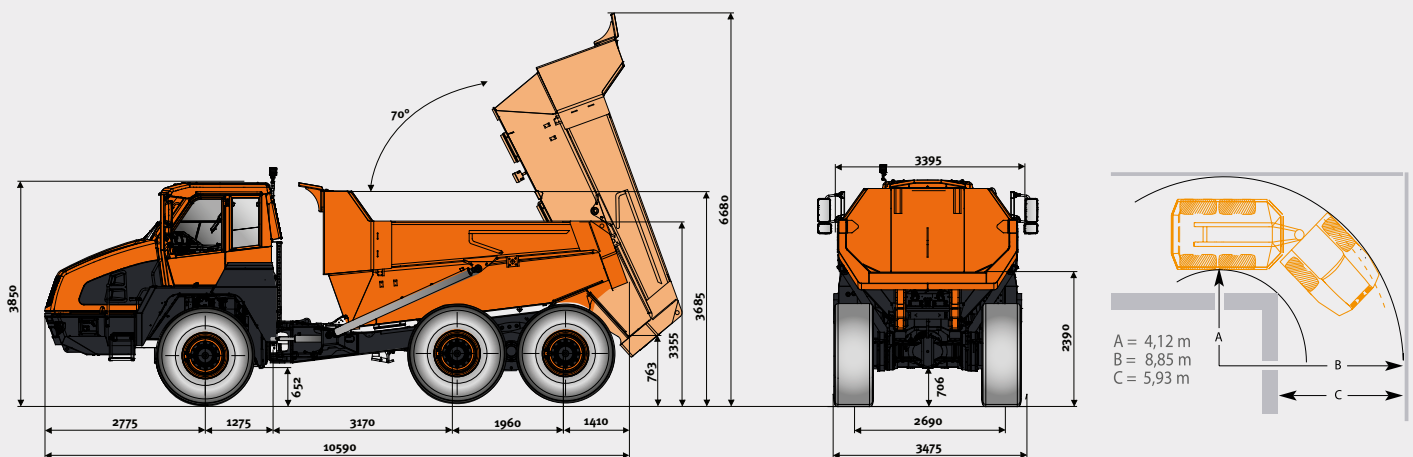

DA45 width with 875/65 R29 tyres: 3630 mm

Turning radius according to ISO 7457: 8.42 m

Special Features

Suspension

Front: Semi-independent, self-leveling hydro-gas suspension

Rear: Free-swinging tandem housing

Articulation hinge and steering

Articulation hinge with forward-mounted turning ring

Steering cylinders (2): Double-acting

The steering is approved according to ISO 5010

Max. steering angle: 45°

Ground-driven emergency steering pump

Driveline

Full-time 6 × 6 drive with 2 transverse differentials and one longitudinal

Front axle transverse differential: Limited-slip diff lock with 45% locking ratio

Rear axle transverse differential: Limited-slip diff lock with 40% locking ratio

Inter-axle longitudinal differential:

- Torque-proportioning differential, integrated into the ZF transmission
- Torque distribution:
 - 1/3 to the front axle
 - 2/3 to the rear axle
- 100% lockable

Tandem housing: Gear driven, free-swinging.

Provides equal drive to rear wheels and ensures the best possible ground contact – whatever the ground conditions

Brake system

Dual circuit braking system

Approved according to ISO 3450

All hydraulic-operated brakes with enclosed oil-cooled wet multiple discs on four hubs (braking force distributed to two hubs by tandem gear wheels)

Spring actuated hydraulic released parking brake, mounted on driveline shaft

Max. gradient, parking brake: 15°

Automatic transmission retarder as standard

Cab

Approved to ROPS/FOPS standards (ISO 3471, ISO 3449)

Low interior sound level: 72 dB(A) (ISO 6395)

External sound level: 108 dB(A) (ISO 6396)

The cab is centrally located on rubber mountings

Hand and arm vibrations are less than 2.5 ms² (ISO 5349-2)

Whole body vibration is less than 0.5 ms² according to ISO 2631-1

Superior visibility - for safer operation

Superior operating controls location

Adjustable suspended operator seat

Adjustable steering column

Climate control – Heater and air conditioning

Tilting for service access

All-around hand rails



Standard & Optional equipment

Standard

Scania, Stage V compliant, SCR, DPF, water-cooled, diesel engine with VGT turbo charger and air-to-air intercooler	▪
1 variable displacement piston pump for steering & tipping	▪
One return flow filter	▪
Armrest at operator seat	▪
Headrest at operator seat	▪
Safety belt at operator and instructor seat	▪
Adjustable steering column	▪
All instrumentation in LCD display	▪
Cigarette lighter	▪
12 V and USB charging point	▪
Retractable roller sunblind	▪
Tinted safety glass	▪
Sliding window (left & right side)	▪
Windshield wiper and washer	▪
Side mirrors	▪
Protection for rear window	▪
Emergency steering, ground-driven	▪
Radio/MP3 and Bluetooth	▪
Cab tilting system	▪
Emergency shutdown switch	▪
Anti-slip steps & platform	▪
Cool box compartment	▪
Storage space	▪
Electronic climate control	▪
High-comfort seat (vertical and longitudinal suspension)	▪
Heated operator seat	▪
Heated mirror	▪
Electrically adjustable mirrors	▪
Gradient meter with anti-flip-over protection system	▪
Payload meter & cycle counter	▪
Wet disc brake	▪
Rear-view camera	▪
Hammer for emergency escape	▪
Hand rails on the fenders	▪

Transmission retarder brake	▪
Automatic lubrication system	▪
DEVELON Fleet Management Web (telematic system)	▪
Mud flaps	▪
Towing hook, front and rear	▪
Work light kit (rear and front)	▪

Optional

Webasto heating system (heat up the cooling system)	▪
Electrical engine heater	▪
Tail gate	▪
Fire extinguisher	▪
First aid kit	▪
Beacon	▪
Light bar	▪
Speed limitation	▪
Work light kit (rear and front) LED	▪
Tool kit	▪
Warning triangle	▪
Fast fill	▪
Tire pressure monitoring system (may not be available with all tires)	▪
Electric diesel refueling pump	▪
Quarry	▪
Earthmoving	▪
Flotation tires	▪



Develon Warranty

Your key to equipment protection and peace on mind

Unlock unparalleled protection for your heavy construction equipment with Develon. Our robust warranties and premium protection plans ensure your investment is safeguarded and adds lasting value.

Tailored warranty plans

Choose from a range of affordable protection plans, designed exclusively for Develon customers through our authorized dealers. These plans turn your machine's price into a strategic investment, not just an expense.

Develon Premium: Premium protection

Opt for Develon Premium to experience unmatched security, reliability, and overall value. This top-tier plan shields your equipment from unexpected costs and minimizes downtime, letting you focus on what matters – getting the job done*.

Act now!

Contact our authorized Develon Dealers today and fortify your equipment investment. With a seamless process and lasting benefits, Develon ensures your heavy construction equipment remains in peak condition.

**Choose Develon Extended Warranty:
Play safe and secure your investments.**

* Only for ADT, HEX and WLO.
Offer may vary based on model.

Powered by Innovation

DEVELON

Space for dealer's stamp

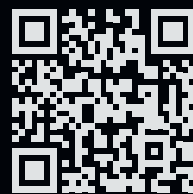

HD Hyundai Infracore Europe s.r.o.
IBC – Pobrezni 620/3,
18600 Praha 8 – Karlín, Czechia

©2024 HD Hyundai Infracore. All rights reserved.

Certain specification(s) are based on engineering calculations and are not actual measurements. Specification(s) are provided for comparison purposes only and are subject to change without notice. Specification(s) for your individual Develon equipment will vary based on normal variations in design, manufacturing, operating conditions, and other factors. Pictures of Develon units may show other than standard equipment.